



A129

Cloud 9
Cabled Pullover



Designed by Melissa Leapman

Cloud 9 Luscious Cabled Pullover

Designed by Melissa Leapman

Sizes

Small (Medium, Large, 1X). Instructions are for smallest size, with changes for other sizes noted in parentheses as necessary.

Finished Measurements

Bust: 34 (41, 48 ½, 56)"

Total length: 22 (22 ½, 23, 23 ½)"

Materials

Cascade Yarn's *Cloud 9*, 11 (12, 13, 14) balls of #152

One pair of sizes 7 and 8 knitting needles or size needed to obtain gauge

One cable needle

Gauge

In Main Cable Patt with larger needles, 26 sts and 26 rows = 4";

In Sleeve Cable Patt with larger needles, 22 sts and 26 rows = 4". **To save time, take time to check gauge.**

Main Cable Patt (*mult 24 + 14 sts*)

See chart.

Contrast Cable Patt (*mult 6 + 2 sts*)

See chart.

Back

With larger needles, CO 110 (134, 158, 182) sts.

Beg Main Cable Patt, and work even until piece measures approx 13" from beg, ending after WS row.

Shape Armholes

BO 4 (12, 14, 20) sts at beg of next two rows, BO 2 (4, 9, 12) sts at beg of next two rows, then dec 1 st each side every row 0 (2, 1, 7) times, then every other row 6 (6, 7, 4) times—86 (86, 96, 96) sts rem.

Cont even in patt as established until piece measures approx 21 (21 ½, 22, 22 ½)" from beg, ending after WS row.

Shape Shoulders

BO 6 (6, 8, 8) sts at beg of next four rows, then BO 7 (7, 8, 8) sts at beg of next two rows—48 sts rem.

BO.

Front

Same as back until piece measures approx 19 (19 ½, 20, 20 ½)" from beg, ending after WS row.

Shape Neck

Work across first 34 (34, 39, 39) sts; join second ball of yarn and BO middle 18 sts, work to end row.

Work both sides at once with separate balls of yarn and BO 6 sts each neck edge once, BO 4 sts each neck edge once, BO 2 sts each neck edge once, then dec 1 st each neck edge every row three times—19 (19, 24, 24) sts rem each side.

Cont even, if necessary, until piece measures same as back to shoulders.

Shape Shoulders

Same as for back.

Sleeves

With larger needles, CO 50 sts.

Beg Contrast Cable Patt, and inc 1 st each side every sixth row 0 (0, 1, 5) times, every eighth row 0 (5, 13, 10) times, then every tenth row 11 (7, 0, 0) times, working new sts into Sleeve Cable Patt as they accumulate—72 (74, 78, 80) sts.

Cont even until sleeve measures approx 18 ½" from beg, ending after WS row.

Shape Cap

BO 4 (12, 13, 20) sts at beg of next two rows, then dec 1 st each side every eighth row 0 (0, 0, 1) time, every sixth row 0 (0, 0, 6) times, every fourth row 0 (7, 9, 0) times, every other row 16 (5, 3, 0) times, then every row 3 (0, 0, 0) times—26 sts rem.

BO 3 sts at beg of next four rows.

BO rem 14 sts.

Finishing

Sew right shoulder seam.

Neckband

With RS facing and smaller needles, pick up and knit 104 sts evenly along neckline.

Work Contrast Cable Patt for 4". BO *loosely* in patt.

Sew left shoulder seam, including side of neckband.

Set in sleeves. Sew sleeve and side seams.

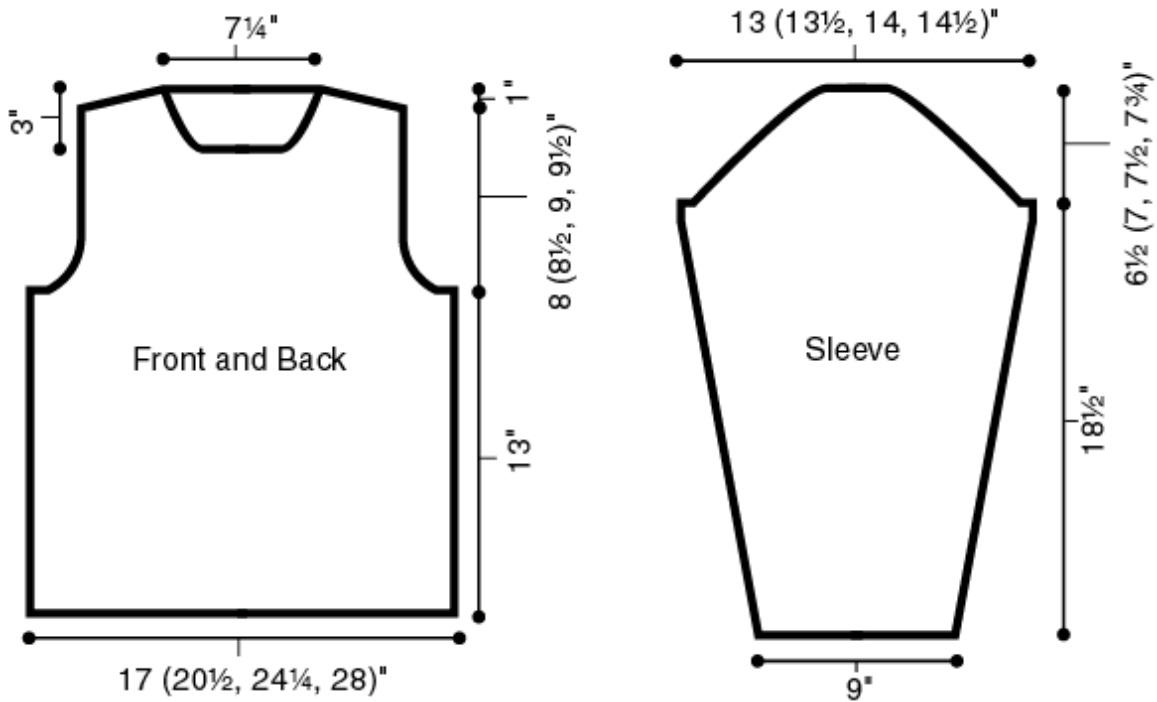

Main Cable Pattern

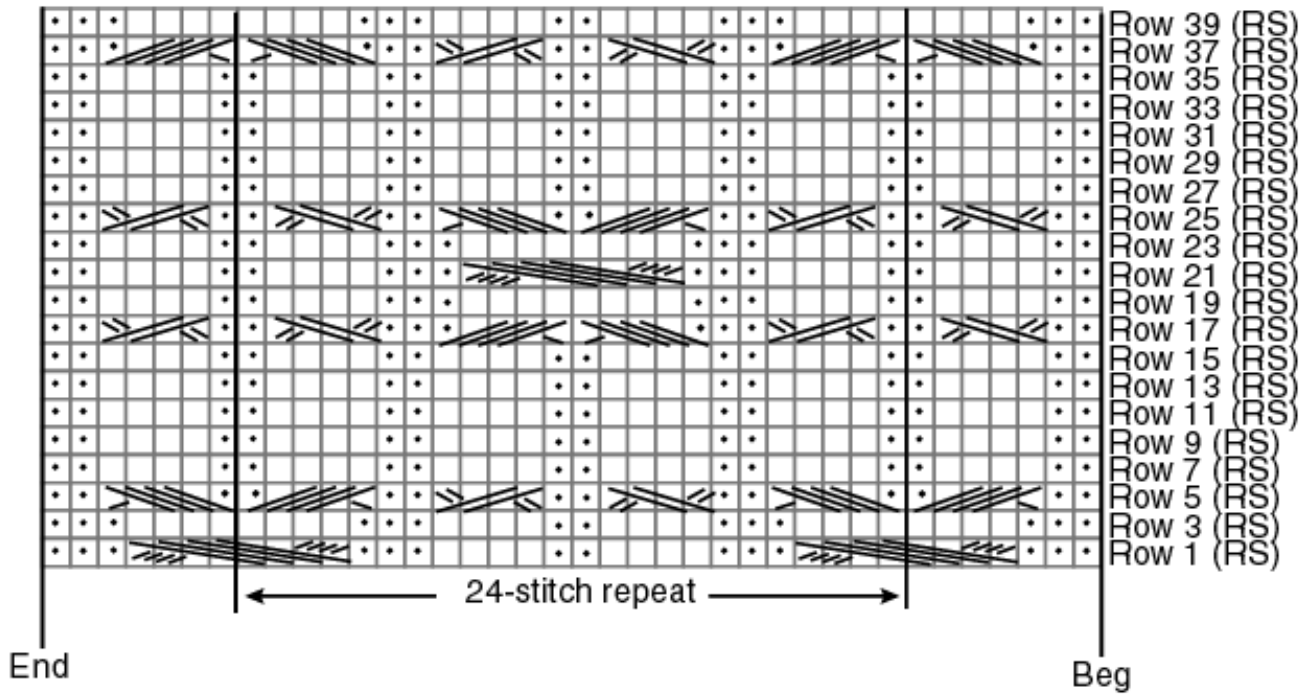

Contrast Cable Pattern

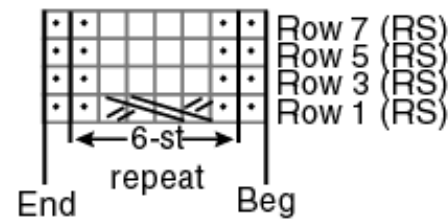

KEY: Note: Only RS rows are shown on chart; for WS rows, knit the knit sts and purl the purl sts!

□ = K

• = P

• / / / / < = Slip next st onto cn and hold in back; K4; P1 from cn

> / / / / • = Slip 4 sts onto cn and hold in front; P1; K4 from cn

/ / / / / / / / = Slip 4 sts onto cn and hold in front; K4; K4 sts from cn

> / / < = Slip 2 sts onto cn and hold in back; K2; K2 from cn

> / / < = Slip 2 sts onto cn and hold in front; K2; K2 from cn